

A

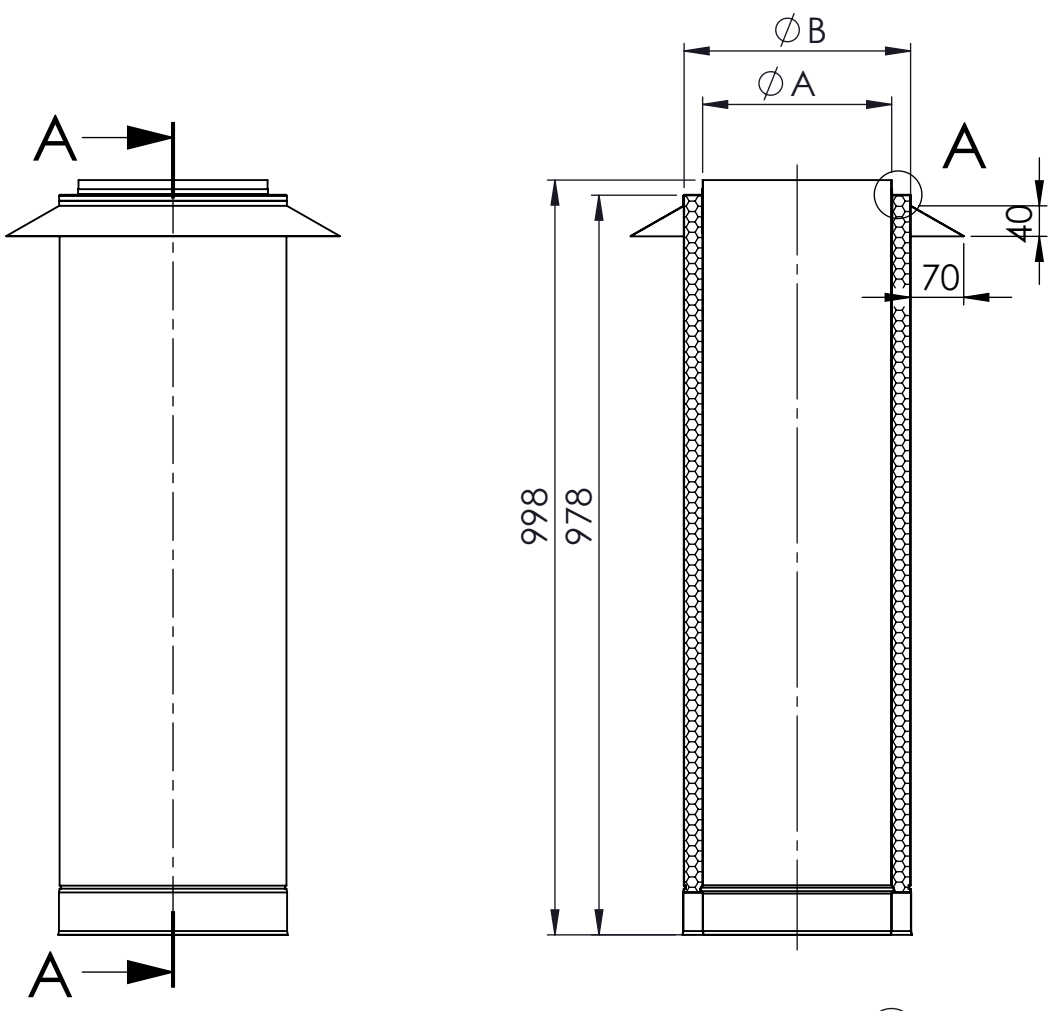

B

C

D

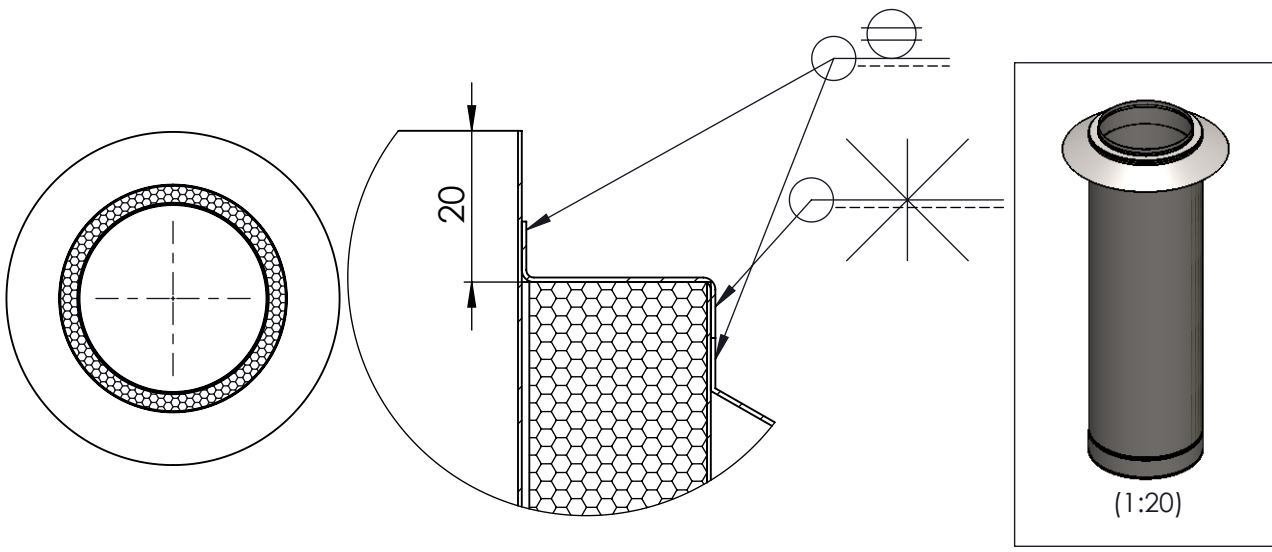

E

ϕ	0080	0100	0115	0120	0130	0140	0150	0160	0180	0200	0225	0250	0300	0350	0400	0450	0500	0550	0600
A	80	100	115	120	130	140	150	160	180	200	225	250	300	350	400	450	500	550	600
B	130	150	165	170	180	190	200	210	230	250	275	300	350	400	450	500	550	600	650
t_i/t_a	0,5 / 0,5																		

F

material: inside/outside		surface: inside/outside		weight:		Jeremias [®] description DW-EC (2.0) 1434 Längenelement 1000mm oben verschl. inkl. Wetterkragen code DW-ECO 2.0 1434 ϕ	
316L/304		mat/shiny		revisions-no. A1			
				date		name	
				drawn		U. Feix	
				checked			
				appr.			
				drawing-no.		A4	
revision		date		name		scale: 1:10	
						sheet 1 of 2	